

LSS-NR

Pan Cake Load Cell



LOAD CELL



DIMENSION

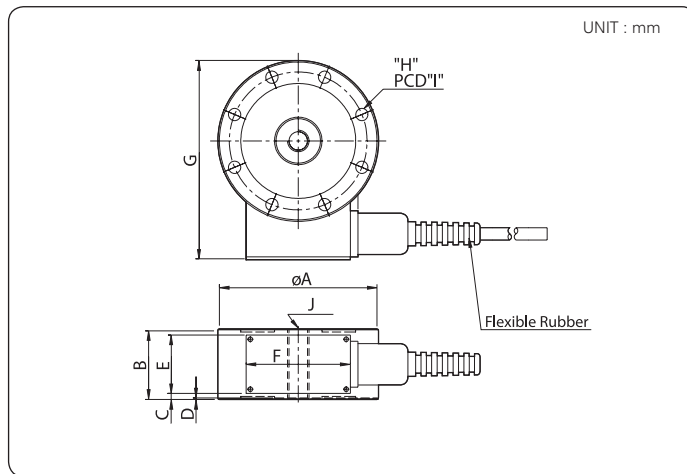

FEATURES

- All stainless steel construction
- Hermetically sealed
- High reliability against fatigue and side force -
- **CE Approved**
- Ex ia IIC T5 Approved(OPTION)

ACCESSORY OPTION

- Accessory for compression
- Accessory for tension
- Ball type accessory

SPECIFICATION

Capa.	A	B	C	D	E	F	G	H	I	J			
1tf													
2tf	112.0	46.0	4.0	1.0	38.0	68.0	141.5	8-Ø7.1	97.2	M16 x 2.0			
3tf													
5tf	120.0	46.0	4.0							149.9	8-Ø9.0	103.2	M18 x 1.5
10tf	138.0	60.0	11.0							169.5	8-Ø11	117.6	M24 x 2.0
20tf	184.0	80.0	21.0				218	8-Ø14	157.6	M39 x 2.0			
30tf													
50tf	200.0	60.0	11.0				234.5	12-Ø14.5	170.0	M45 x 3.0			

Capacity		tf	1, 2, 3, 5, 10, 20, 30, 50
Rated Output		mV / V	2.0 ± 0.005
Zero Balance		mV / V	0.0 ± 0.020
Accuracy Class		-	-
Non-Linearity		% R.O.	≤ 0.03
Hysteresis		% R.O.	≤ 0.03
Combined Error		% R.O.	≤ 0.03
Repeatability		% R.O.	≤ 0.02
Creep for 30min.		% R.O.	≤ 0.03
Return for 30min.		% R.O.	≤ 0.03
Resolution		-	< 1/3000
Division		mV / V	0.0006
Temperature Effect on	-Zero Value	%/10°C	≤ 0.03
	-Output Value	%/10°C	≤ 0.03
Excitation	-Recommended	V	10
	-Maximum	V	15
Resistance	-Input	Ω	350 ± 3.5
	-Output	Ω	350 ± 3.5
	-Insulation	MΩ	> 2000
Compensated Temperature Range		°C	- 10 to +40
Operating Temperature Range		°C	- 20 to +80
Material & Plate		-	Stainless steel
Cable Specification		-	∅8 x 4P x 5M(5M) ≤ LSS-10, ∅8 x 4P x 5M(10M) ≥ LSS-20
Safety Overload		% R.L.	150% R.L.
Platform Size		mm	No Platform type

SINGLE POINT
BENDING & SHEAR
S-BEAM
CANISTER
PANCake & MINIATURE
TRUCK & TANK WEIGHING
SPECIAL APPLICATION